

# HYXinbattery Rack Series Battery Packs

## Data Parameters HYX-48150R1

### HYXinbattery 48V 150Ah LiFePO4 LITHIUM BATTERY

Crafted out of Lithium Iron Phosphate (LiFePO4) technology, this is a battery built to last. With 3,000+ recharge cycles (and up to 7,000 @50%DOD) the 100 Ah provides 5 X the lifespan than your typical SLA battery. Built in smart BMS which can realize real-time monitoring the battery, Compatible with inverters of multiple brands, which can support 16 units parallel connection.

#### SPECIFICATIONS

Nominal Voltage	51.2V
Rated Capacity	150AH @0.2C to 40V
Stored energy	7680Wh
Cycle life@100%DOD	>3000 Cycles@100%DOD >4000 Cycles@80%DOD >7000 Cycles@50%DOD
Approx. Weight	62 kg
Internal Resistance	≤70.0 mΩ
Max. Charge Current	50 A
Max. Discharge Current	100 A
Charge Cut-off Voltage	58.4V
Discharge Cut-Off Voltage	40V
Dimensions	L483mm × W520mm × H178mm
Series & Parallel Connection	Maxium 16 units in parallel Connection
Operating Temperature Range	
Charge	32°F (0°C) to 113°F (45°C)
Discharge	-4°F (-20°C) to 140°F (60°C)
Storage	-4°F (-20°C) to 140°F (60°C)
Self-Discharge Rate	≤3%/month @ 25° C
Life Expectancy (years)	10 years @ 25° C
Communication Port	RS485, RS2332, CAN



#### COMPLIED STANDARD

- ✓ IEC 62133
- ✓ UL 1642
- ✓ ISO9001
- ✓ ISO14001
- ✓ UN38.3
- ✓ RoHS

#### INTELLIGENT BMS FUNCTION

- Over charge protection function
- Over discharge protection function
- Over current protection function
- Short-circuit protection function
- Temperature protection function
- Cell Balance function
- Communicate function
- Alarm function

#### APPLICATIONS

RESS    BESS    Back-up system    Data center    Telecon    Energy storage system

**CHARACTERISTIC CURVE**

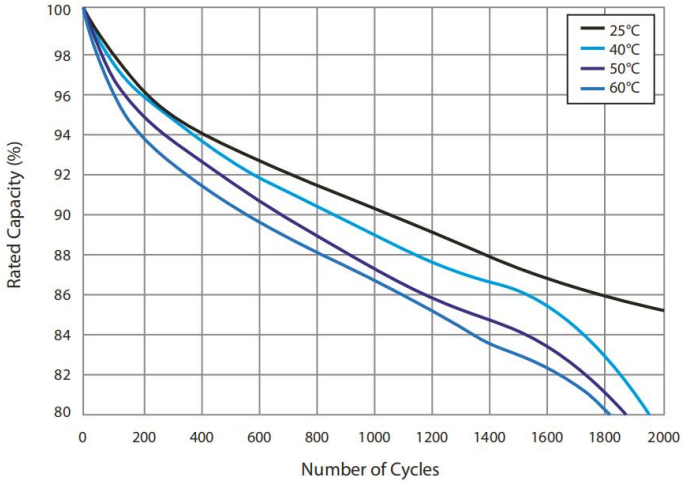

**100% DOD Cycle Curves at Different Temperatures**

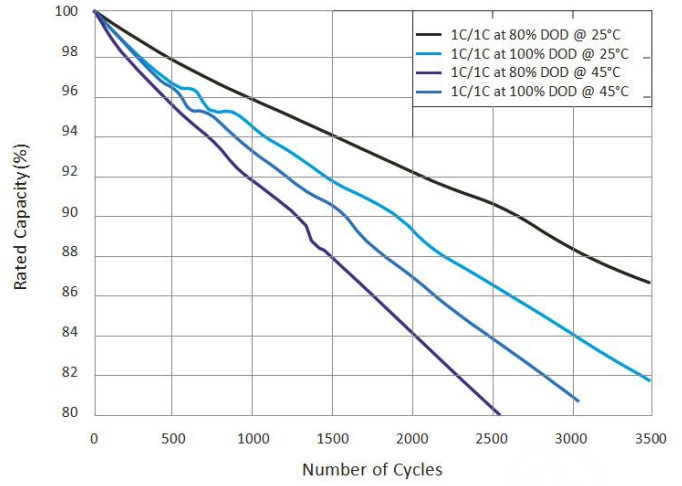

**1C Cycle Curves at Different DOD & Temperatures**

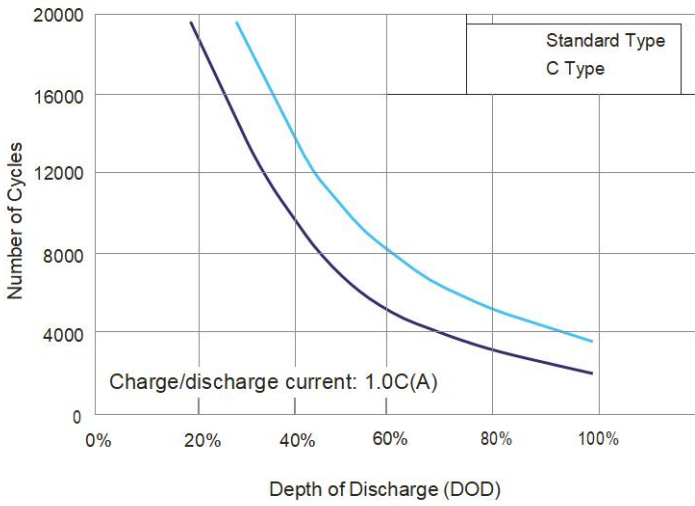

**DOD in Relation to Cycle Life (25°C)**

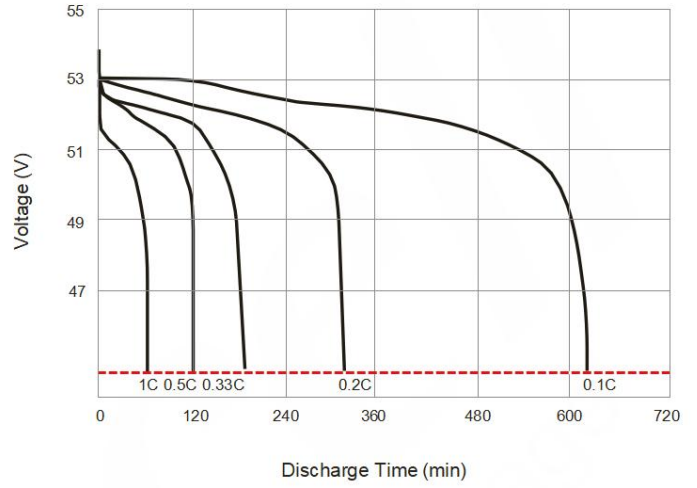

**Discharge Time in Relation to Discharge Rate (25°C)**

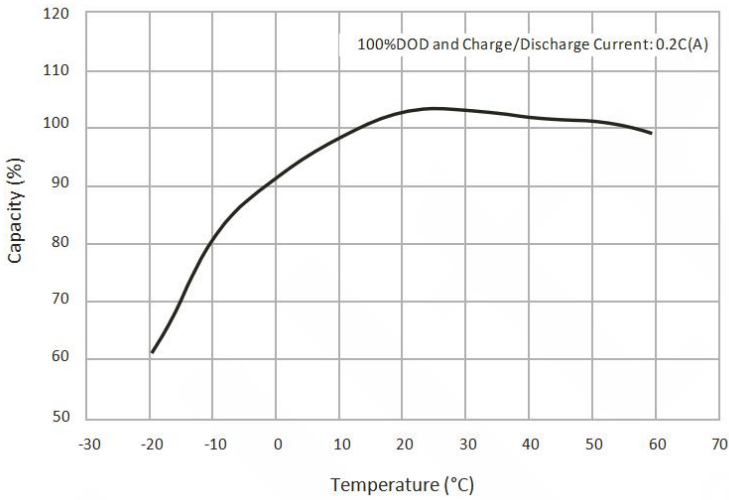

**Temperature Effect in Relation to Battery Capacity**

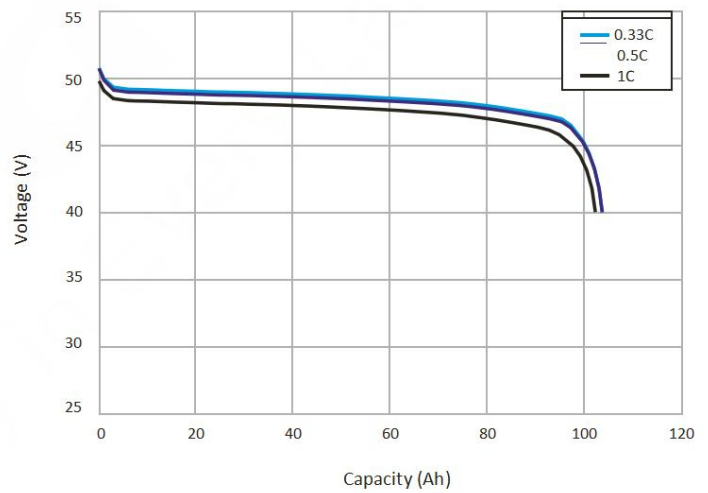

**Discharge Capacity in Relation to Discharge Rate**

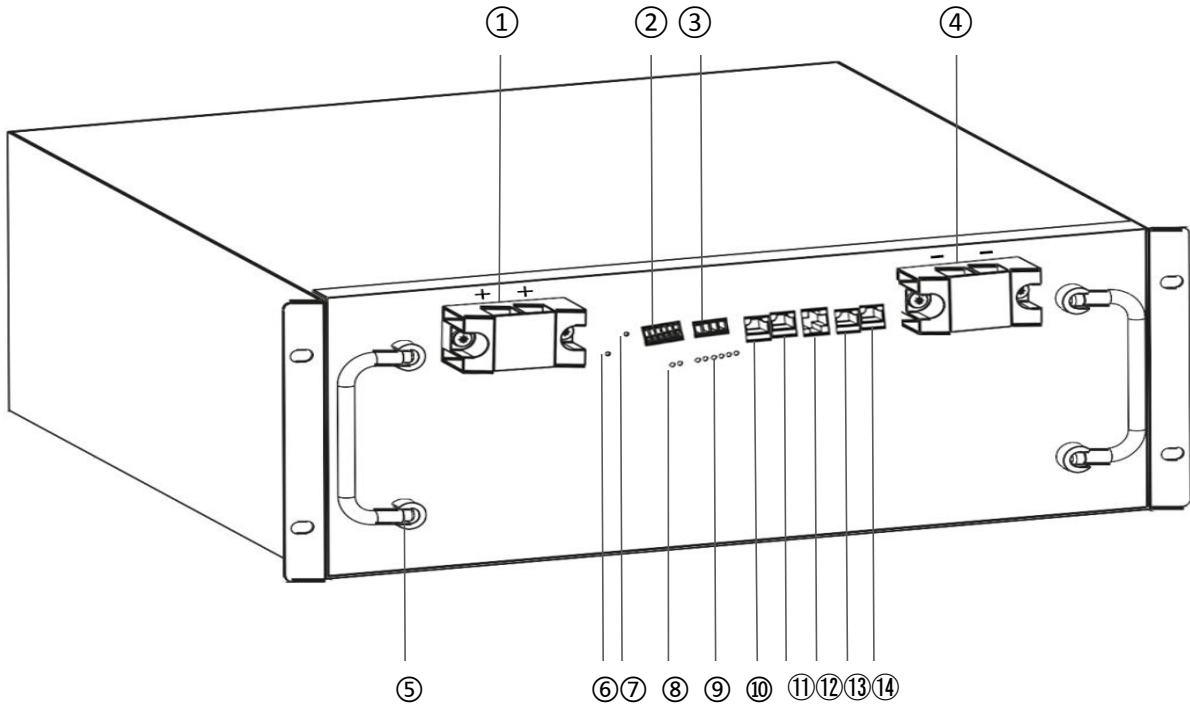

① Positive Terminal

② ADD Dialer

③ DRY CONTACT

④ Negative Terminal

⑤ SS Handle

⑥ ON/OFF Button

⑦ Reset Key

⑧ Run Indicator Light

⑨ Electricity Volume Indicator

⑩ RS485 Port

⑪ CAN Port

⑫ RS232 Port

⑬ RS485 Port

⑭ RS485 Port

#### BATTERY DIMENSIONS

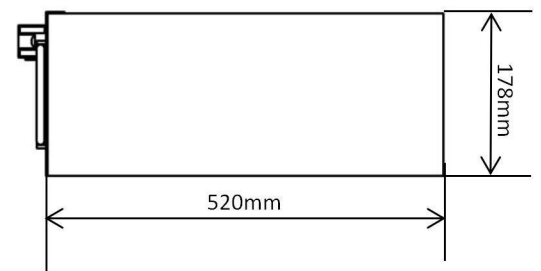
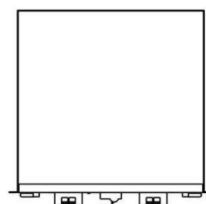
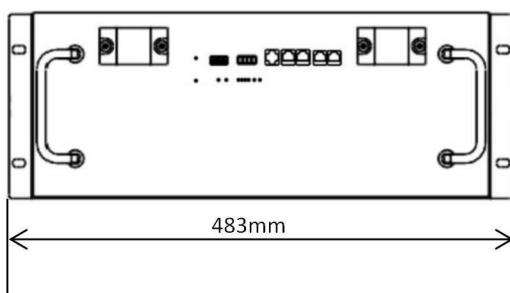

### Shenzhen Heyuxin Technology Co.,Ltd

2001, Building A, Zhongan Science Park, No. 117,  
Huaning Road, Xinshi Community, Dalang Street, Longhua District,  
Shenzhen, Guangdong

Website: [www.hyxinbattery.com](http://www.hyxinbattery.com)  
Email: [contact@hyxinbattery.com](mailto:contact@hyxinbattery.com)

